

10 kPa Uncompensated Silicon Pressure Sensors

The MPX10 and MPXV10GC series devices are silicon piezoresistive pressure sensors providing a very accurate and linear voltage output — directly proportional to the applied pressure. These standard, low cost, uncompensated sensors permit manufacturers to design and add their own external temperature compensation and signal conditioning networks. Compensation techniques are simplified because of the predictability of Freescale's single element strain gauge design. Figure 1 shows a schematic of the internal circuitry on the stand-alone pressure sensor chip.

Features

- Low Cost
- Patented Silicon Shear Stress Strain Gauge Design
- Ratiometric to Supply Voltage
- Easy to Use Chip Carrier Package Options
- Differential and Gauge Options
- Durable Epoxy Unibody Element or Thermoplastic (PPS) Surface Mount Package

Functional Description

- Air Movement Control
- Environmental Control Systems
- Level Indicators
- Leak Detection
- Medical Instrumentation
- Industrial Controls
- Pneumatic Control Systems
- Robotics

ORDERING INFORMATION ⁽¹⁾				
Device Type	Options	Case No.	Order Number	Device Marking
SMALL OUTLINE PACKAGE (MPXV10G SERIES)				
Ported Elements	Rails	482A	MPXV10GC6U	MPXV10G
	Tape and Reel	482A	MPXV10GC6T1	MPXV10G
	Rails	482C	MPXV10GC7U	MPXV10G
UNIBODY PACKAGE (MPX10 SERIES)				
Basic Element	Differential	344	MPX10D	MPX10D
Ported Elements	Differential	344C	MPX10DP	MPX10DP
	Gauge	344B	MPX10GP	MPX10GP
	Gauge	344E	MPX10GS	MPX10D

1. MPX10 series pressure sensors are available in differential and gauge configurations. Devices are available in the basic element package or with pressure port fittings which provide printed circuit board mounting ease and barbed hose pressure connections.

MPX10 MPXV10GC SERIES

UNCOMPENSATED PRESSURE SENSOR
0 TO 10 kPa (0–1.45 psi)
35 mV FULL SCALE SPAN
(TYPICAL)

SMALL OUTLINE PACKAGES

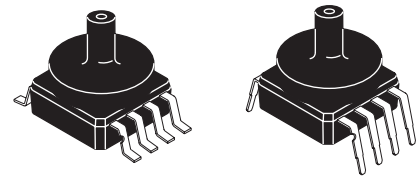

MPXV10GC6U
CASE 482A-01

MPXV10GC7U
CASE 482C-03

SMALL OUTLINE PACKAGE PIN NUMBERS

1	GND	5	N/C
2	+V _{out}	6	N/C
3	V _s	7	N/C
4	-V _{out}	8	N/C

NOTE: Pin 1 is noted by the notch in the lead.

UNIBODY PACKAGE PIN NUMBERS

1	GND	3	V _s
2	+V _{out}	4	-V _{out}

NOTE: Pin 1 is noted by the notch in the lead.

UNIBODY PACKAGES

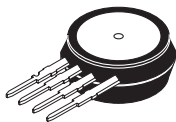

MPX10D
CASE 344-15

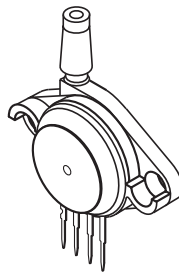

MPX10GP
CASE 344B-01

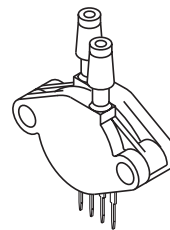

MPX10DP
CASE 344C-01

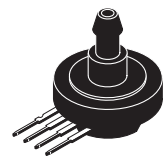

MPX10GS
CASE 344E-01

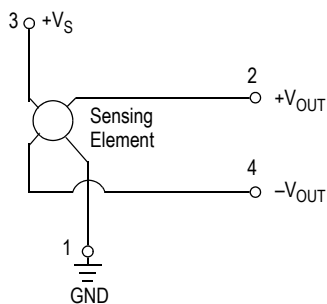

Figure 1. Uncompensated Pressure Sensor Schematic

VOLTAGE OUTPUT VERSUS APPLIED DIFFERENTIAL PRESSURE

The output voltage of the differential or gauge sensor increases with increasing pressure applied to the pressure side (P1) relative to the vacuum side (P2). Similarly, output

voltage increases as increasing vacuum is applied to the vacuum side (P2) relative to the pressure side (P1).

Table 1. Maximum Ratings⁽¹⁾

Rating	Symbol	Value	Unit
Maximum Pressure (P1 > P2)	P_{MAX}	75	kPa
Burst Pressure (P > P2)	P_{BURST}	100	kPa
Storage Temperature	T_{STG}	-40 to +125	°C
Operating Temperature	T_A	-40 to +125	°C

1. Exposure beyond the specified limits may cause permanent damage or degradation to the device.

Table 2. Operating Characteristics ($V_S = 3.0$ Vdc, $T_A = 25^\circ\text{C}$ unless otherwise noted, $P_1 > P_2$)

Characteristic	Symbol	Min	Typ	Max	Units
Differential Pressure Range ⁽¹⁾	P_{OP}	0	—	10	kPa
Supply Voltage ⁽²⁾	V_S	—	3.0	6.0	V _{DC}
Supply Current	I_O	—	6.0	—	mAdc
Full Scale Span ⁽³⁾	V_{FSS}	20	35	50	mV
Offset ⁽⁴⁾	V_{OFF}	0	20	35	mV
Sensitivity	$\Delta V/\Delta P$	—	3.5	—	mV/kPa
Linearity ⁽⁵⁾	—	-1.0	—	1.0	% V_{FSS}
Pressure Hysteresis ⁽⁵⁾ (0 to 10 kPa)	—	—	±0.1	—	% V_{FSS}
Temperature Hysteresis ⁽⁵⁾ (-40°C to +125°C)	—	—	±0.5	—	% V_{FSS}
Temperature Coefficient of Full Scale Span ⁽⁵⁾	TCV_{FSS}	-0.22	—	-0.16	% $V_{FSS}/^\circ\text{C}$
Temperature Coefficient of Offset ⁽⁵⁾	TCV_{OFF}	—	±15	—	$\mu\text{V}/^\circ\text{C}$
Temperature Coefficient of Resistance ⁽⁵⁾	TCR	0.28	—	0.34	%/ $Z_{IN}/^\circ\text{C}$
Input Impedance	Z_{IN}	400	—	550	Ω
Output Impedance	Z_{OUT}	750	—	1250	Ω
Response Time ⁽⁶⁾ (10% to 90%)	t_R	—	1.0	—	ms
Warm-Up Time ⁽⁷⁾	—	—	20	—	ms
Offset Stability ⁽⁸⁾	—	—	±0.5	—	% V_{FSS}

- 1.0 kPa (kiloPascal) equals 0.145 psi.
- Device is ratiometric within this specified excitation range. Operating the device above the specified excitation range may induce additional error due to device self-heating.
- Full Scale Span (V_{FSS}) is defined as the algebraic difference between the output voltage at full rated pressure and the output voltage at the minimum related pressure.
- Offset (V_{OFF}) is defined as the output voltage at the minimum rated pressure.
- Accuracy (error budget) consists of the following:
 - Linearity: Output deviation from a straight line relationship with pressure, using end point method, over the specified pressure range.
 - Temperature Hysteresis: Output deviation at any temperature within the operating temperature range, after the temperature is cycled to and from the minimum or maximum operating temperature points, with zero differential pressure applied.
 - Pressure Hysteresis: Output deviation at any pressure with the specified range, when this pressure is cycled to and from the minimum or maximum rated pressure at 25°C.
 - TcSpan: Output deviation at full rated pressure over the temperature range of 0 to 85°C, relative to 25°C.
 - TcOffset: Output deviation with minimum rated pressure applied, over the temperature range of 0 to 85°C, relative to 25°C.
 - TCR: Z_{IN} deviation with minimum rated pressure applied, over the temperature range of -40°C to ±125°C, relative to 25°C.
- Response Time is defined as the time from the incremental change in the output to go from 10% to 90% of its final value when subjected to a specified step change in pressure.
- Warm-up Time is defined as the time required for the product to meet the specified output voltage after the pressure is stabilized.
- Offset stability is the product's output deviation when subjected to 1000 hours of Pulsed Pressure, Temperature Cycling with Bias Test.

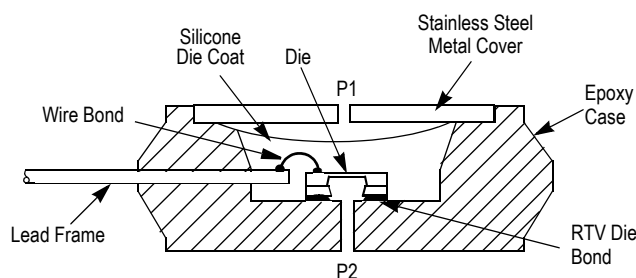

Figure 4. Unibody Package — Cross-Sectional Diagram (Not to Scale)

Figure 4 illustrates the differential or gauge configuration in the basic chip carrier (Case 344). A silicone gel isolates the die surface and wire bonds from the environment, while allowing the pressure signal to be transmitted to the silicon diaphragm.

The MPX10 and MPXV10GC series pressure sensor operating characteristics and internal reliability and

qualification tests are based on use of dry air as the pressure media. Media other than dry air may have adverse effects on sensor performance and long term reliability. Contact the factory for information regarding media compatibility in your application.

PRESSURE (P1)/VACUUM (P2) SIDE IDENTIFICATION TABLE

Freescle designates the two sides of the pressure sensor as the Pressure (P1) side and the Vacuum (P2) side. The Pressure (P1) side is the side containing silicone gel which isolates the die from the environment. The Freescle pressure sensor is designed to operate with positive differential pressure applied, $P1 > P2$.

The Pressure (P1) side may be identified by using the following table.

Part Number	Case Type	Pressure (P1) Side Identifier
MPX10D	344	Stainless Steep Cap
MPX10DP	344C	Side with Part Marking
MPX10GP	344B	Side with Port Attached
MPX10GS	344E	Side with Port Attached
MPXV10GC6U	482A	Side with Part Marking
MPXV10GC7U	482C	Side with Part Marking